

PEERLESS

TECH SPEC

LIQUEFIED NATURAL GAS



Complete Separation and Filtration Solutions for **LIQUEFIED NATURAL GAS**

Efficiently Designed Separation Systems

Economic Leverage

Technology Leadership

REDUCED LNG COSTS WITH STATE-OF-THE-ART SEPARATION AND FILTRATION FOR YOUR ENTIRE PLANT

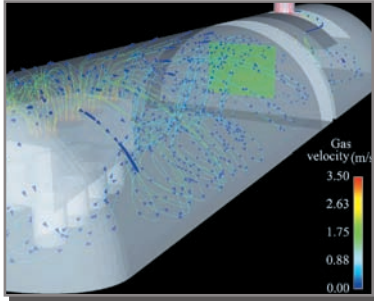

A CFD model represents the final design of a Peerless gas separator for an LNG facility. Vector and contour plots provide the engineer with confirmation that the gas velocities in the vessel meet established separation design criteria.



Peerless separation equipment is used across the energy industry.

PEERLESS SEPARATORS AND FILTERS PROVIDE A MAJOR ECONOMIC ADVANTAGE FOR OWNERS AND CONSTRUCTORS OF LNG FACILITIES.

- Vessels several sizes smaller than conventional “mesh pad” designs, yet that efficiently meet all specified operating parameters.
- Support structure and space savings with smaller and lighter separation and filtration vessels.
- Lower system costs, particularly where low operating temperatures require stainless steel materials.
- Sole source responsibility – Peerless provides full mechanical and operating performance guarantees.

PEERLESS TECHNOLOGY PROVIDES ECONOMIC ADVANTAGE.

Research and Development Peerless separation and filtration systems are designed by scientists and engineers who use technology to support their knowledge and experience. Peerless has more than six decades of experience and has built an impressive record of achievement in separation technology through the combination of computational analysis, laboratory measurements and field tests.

Computational Fluid Dynamics (CFD) Sophisticated in-house Computational Fluid Dynamics (CFD) computer models help to reduce the size of separation and filtration vessels and ensure that liquid and vapor separation is achieved to specification. Actual LNG vapor and liquid properties are used in these CFD models to determine the overall separation efficiency and capacity.

Research and Development Laboratory Our research and development laboratory enables Peerless scientists to design experiments and perform tests that validate cost-effective separation and filtration solutions that are customized for the LNG process.

In-Line Testing Without Plant Shutdown Peerless has developed a field sampling tool for pressurized gas streams. The Laser Isokinetic Sampling Probe (LISPSM) extracts gas samples with entrained liquids and solids in their pressurized state isokinetically. Meticulous measurements can be made both up- and down-stream of separators or filters to quantify the solid and liquid amounts and size distributions in the gas pipeline. The result is the most accurate and reliable field sampling of LNG processes without a plant shutdown.

YOUR GAS SEPARATORS DIRECTLY AFFECT YOUR BOTTOM LINE

- Efficiency
 - Remove liquid and solid contaminants simultaneously.
 - Protect downstream equipment.
 - Optimize operations.
- Economic Benefits
 - Less process contamination.
 - Less damage to your processing equipment.
 - Lower product, solvent and reagent losses.
 - Lower installed cost with Peerless equipment.

Innovative Designs
Cost Effective Retrofits
Guaranteed Performance

PEERLESS PERFORMANCE GUARANTEE

We are not limited to traditional separation concepts. Our extensive product line, superior research and technology capabilities and multiple fabrication shops set Peerless apart. We guarantee our separators to meet your specifications.

PEERLESS DESIGNED AND MANUFACTURED PRODUCTS IN A TYPICAL LIQUEFIED NATURAL GAS PROCESS

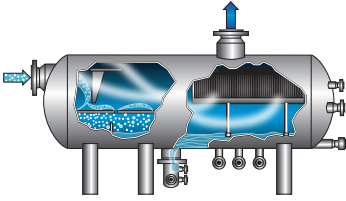

Peerless Horizontal Gas Separator
Designed for high efficiency separation of liquids from the gas stream.

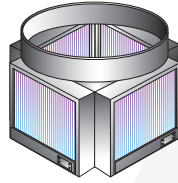

Peerless Mist Extractor Internals at the top of a gas process tower provide high efficiency separation and protect downstream equipment.

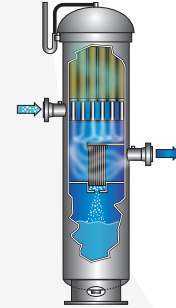

The Peerless Filter/Separator
Saves on initial cost, filter cartridge change-out time and space. High capacity inertial vanes remove coalesced liquid droplets from the gas stream.

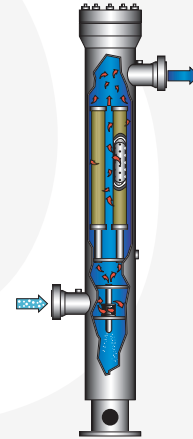
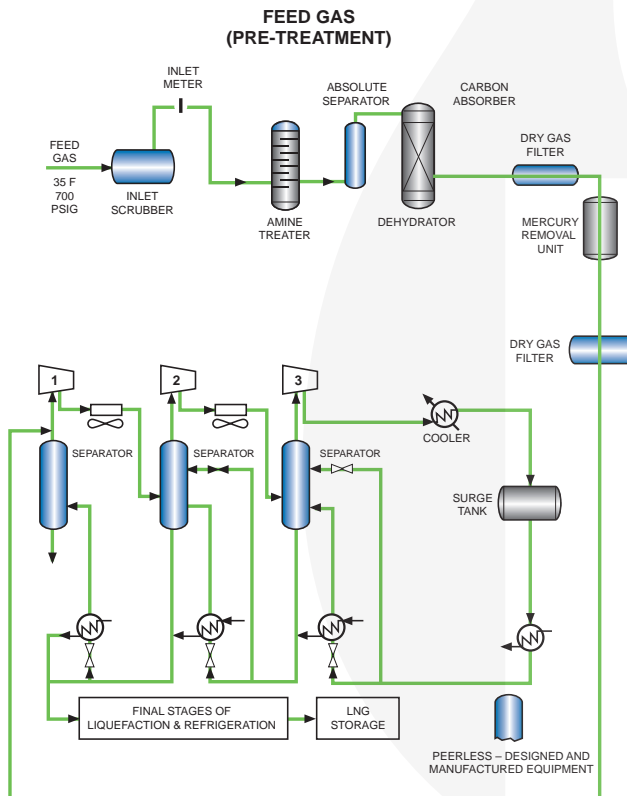

Absolute Separator
Provides ultra-high efficiency for the removal of submicron liquid droplets.

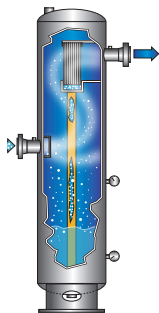

Peerless Vertical Gas Separators
Very efficient mist extractors in applications where high liquid capacity is required.

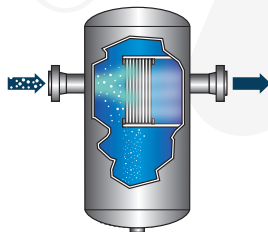

The Line Separator
Used to remove entrained liquids. It can be installed as an in-line unit.

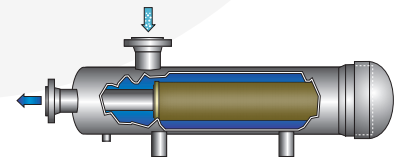

Peerless Dry Gas Filters
Designed for maximum operating and change-out efficiency. A quick-release filter cartridge retainer saves on replacement time and costs.

Peerless has corrected existing separator problems cost effectively since the 1930's. Our extensive retrofit experience is a valuable benefit for your company. We understand operating problems, have the latest technology and know all the options. You can count on us to keep your separators out of trouble. Call a Peerless Applications Engineer Today!

PEERLESS...YOUR GAS PROCESSING
PROBLEM SOLVER

Throughout the gas processing industry, you'll certainly find entrained liquids and solids in the gas stream. Everywhere you do, think about applying Peerless separation and filtration systems. With over seventy years of experience, we've seen most process entrainment problems. Peerless Mfg. Co. is a world leader in separation and filtration technology and equipment. We're in the business of solving problems related to entrainment removal. Peerless offers a full range of separators in unique configurations. We evaluate your problem, recommend what you need, and can develop a custom system solution to fit your particular application.



MAKING ENERGY SAFE, EFFICIENT, AND CLEAN.

Peerless Europe Limited
Cardinal's Court, Bradford St.
Braintree, Essex CM7 9AT
United Kingdom
Phone +44 (0)1376-556030
Fax +44 (0)1376-556059
www.peerlesseurope.com
sales@peerlesseurope.com

Peerless Mfg. Co.
14651 North Dallas Parkway
Suite 500
Dallas, TX 75254, USA
Phone +1 214-357-6181
www.peerlessmfg.com
NASDAQ Symbol: PMFG

Peerless Mfg. Co.
Regional Office
35 Jalan Pemimpin, #07-02
Singapore 577176
Phone +65 6354-2306

Peerless Manufacturing Canada Ltd.
5329 1A Street SW
Calgary Alberta T2H 0E5
Canada
Phone 403-252-2600